

# Relays

## Power relays

Characteristic quantities					
Rated voltage (switching and excitation circuit)	12 V (type 1)	24 V (type 1)	12 V (type 2)	24 V (type 2)	12 V (type 3)
Operating voltage	8...14,5 V	16...27 V	15 V	30 V	8...16 V
Ambient temperature	-40...+100 °C	-40...+100 °C	-40...+65 °C <sup>1)</sup>	-40...+65 °C <sup>1)</sup>	-40...+100 °C
Voltage drop at measurement current in as-new condition	≤ 200 mV/50 A	≤ 150 mV/20 A	≤ 100 mV <sup>2)</sup> /75 A	≤ 100 mV/75 A	≤ 100 mV/100 A
Voltage drop after specified switching operations	≤ 225 mV/50 A		≤ 200 mV <sup>3)</sup> /75 A	≤ 200 mV/75 A	
Housing/terminal degree of protection (refer to Page 5)	IP 20 <sup>4)</sup> /IP 20	IP 20 <sup>4)</sup> /IP 20	IP 54 /IP 00	IP 54 /IP 00	IP 67 /IP 20

<sup>1)</sup> +100 °C for short-term operation with 25% operating time relative to 2 minutes. <sup>2)</sup> ≤ 50 mV/75 A for double contact relay 0 332 002 150. <sup>3)</sup> ≤ 100 mV/75 A for double contact relay 0 332 002 150. <sup>4)</sup> Housing protection type IP 5K4 when using a receptacle housing with installation position at lower connector.

### Notes

- Compact design.
  - High degree of corrosion protection due to use of glass-fiber-reinforced polyamide for baseplate and cap.
  - High degree of protection against splash water thanks to drip rim between cap and baseplate.
  - Leakage-current barriers in baseplate.
  - Designed-in ventilation by means of “labyrinth”.
  - Option of “heavy duty” version with tungsten leading contact.
- Automotive applications:**
- Load-reducing relay for switches.
  - Operating relay for starting motors.
  - Switch-on relay for hydraulic assemblies, slowers and heaters
- for the passenger compartment, engine-cooling fans.
  - Pre-heating device for diesel starting systems.
  - Motor relay for antilock braking system (ABS).
  - Battery cutoff relay.
- Accessories**  
see page 40

### Method of operation of leading contact

**1. Closure of leading contact**  
Coil energized; current flows in leading contact for a fraction of a second.

**2. Closure of main contact**  
Coil energized; current flows in main contact. The characteristics of the tungsten leading contact make it ideal for the considerable loads resulting from the separation arc when contacts are opening (inductive loads). The main

contact ensures efficient current flow with minimum voltage losses. The tungsten leading contact (late-opening when the contacts open) ensures that the main contacts are not subject to separation arcs.

# Relays

## Power relays

### Make relay 12 V type 1

**0 332 002 192**

#### Technical data

Resistive load	Switching current/no. of operations	A/Thousand	50 / $\geq 100$
Resistive load	Short-time load $\leq 1$ s	A	120
Motor load	Making curr./cont.curr./no. of operations	A/A/Thousand	86/55 / $\geq 130$
Response/release voltage		V/V	$\leq 6,0/1,0...5,0$
Response/release time		ms/ms	$\leq 10 / \leq 10$
Contact type			single
Bracket			plugged in
Overall resistance		$\Omega$	$45 \pm 5$

#### Dimensional drawing

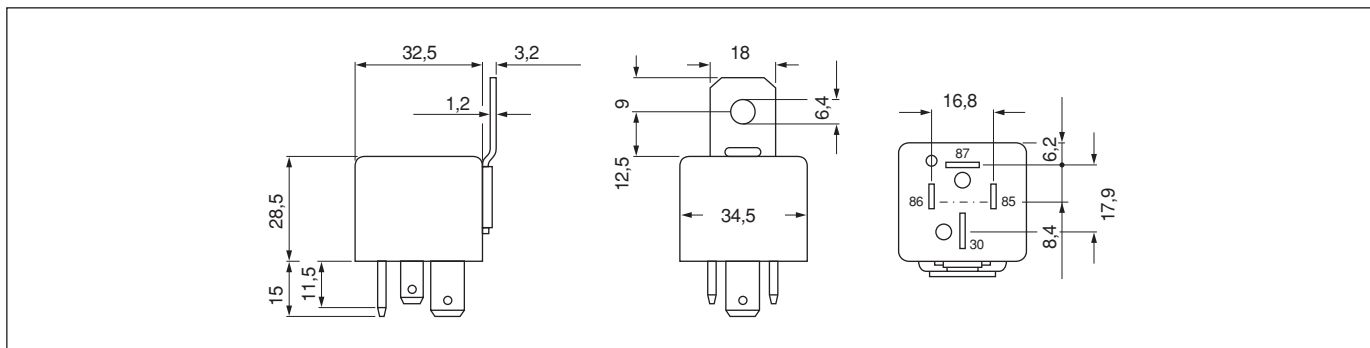

Blade terminal connections: Excitation side terminals 85 and 86: 6.3 x 0.8 mm; Contact side terminals 30 and 87: 9.5 x 1.2 mm

#### Figure



#### Connection and circuit diagram

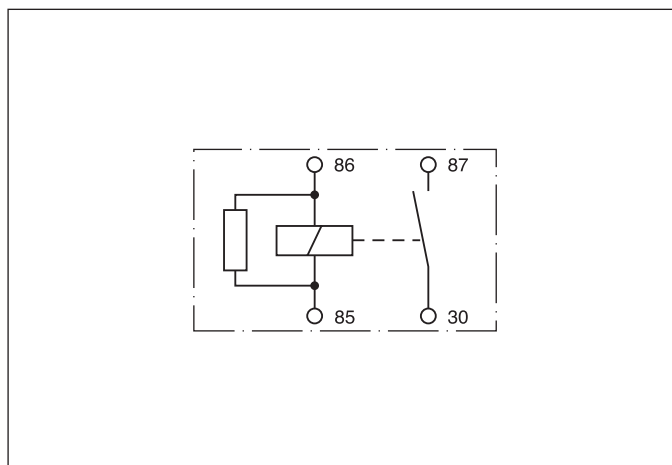

Polarity: Terminal 86 and terminal 30 to +



# Relays

## Power relays

### Make relay 12 V type 2

**0 332 002 150**

#### Technical data

Resistive load	Switching current/no. of operations	A/Thousand	75 / $\geq$ 125
Resistive load	Short-time load $\leq$ 1 s	A	400
Response/release voltage		V/V	$\leq$ 8,0/1,5...4,0
Response/release time		ms/ms	$\leq$ 10 / $\leq$ 15
Contact type			twin
Bracket			fixed
Overall resistance		$\Omega$	46 $\pm$ 5

#### Dimensional drawing

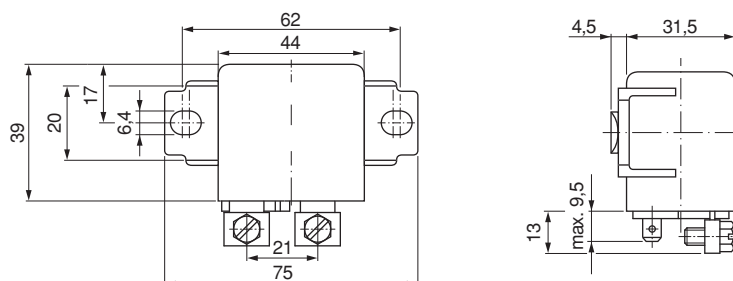

Accessories: Double receptacle housing for excitation side (terminals 85 and 86). Order using Tyco (AMP) number 180 907 from: Tyco (AMP) Deutschland GmbH, Amperestraße 7-11, D-63225 Langen, Tel. 0 61 03/70 90.

#### Figure

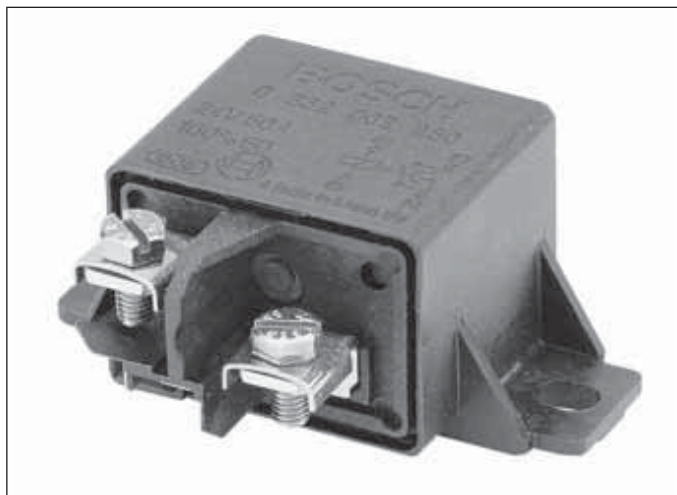

#### Connection and circuit diagram

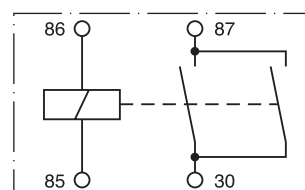

Polarity: Terminal 86 and terminal 30 to +

# Relays

## Power relays

### Make relay 12 V type 2

0 332 002 156

#### Technical data

Resistive load	Switching current/no. of operations	A/Thousand	75 / $\geq 100$
Resistive load	Short-time load $\leq 1$ s	A	250
Response/release voltage		V/V	$\leq 8,5/1,0 \dots 4,0$
Response/release time		ms/ms	$\leq 10 / \leq 15$
Contact type			single
Bracket			fixed
Overall resistance		$\Omega$	$46 \pm 5$

#### Dimensional drawing

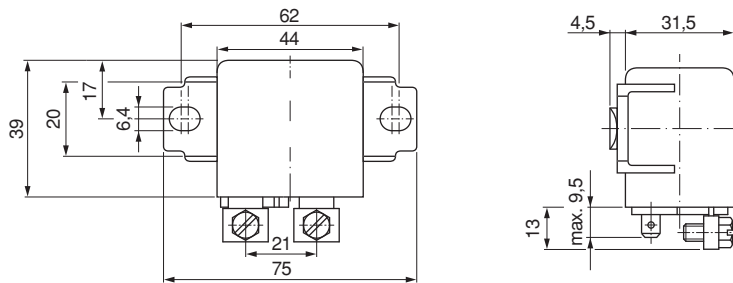

Accessories: Double receptacle housing for excitation side (terminals 85 and 86). Order using Tyco (AMP) number 180 907 from: Tyco (AMP) Deutschland GmbH, Amperestraße 7-11, D-63225 Langen, Tel. 0 61 03/70 90.

#### Figure

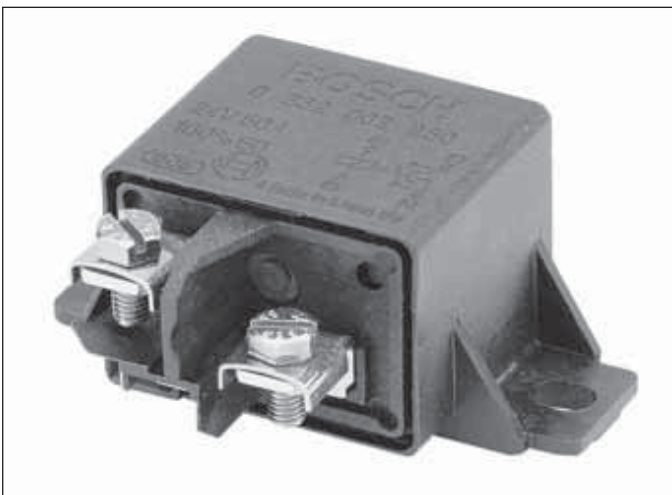

#### Connection and circuit diagram

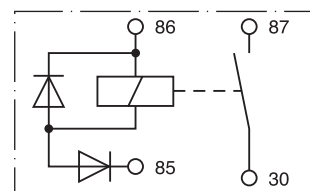

Polarity: Terminal 86 and terminal 30 to +

# Relays

## Power relays

### Make relay 12 V type 2

**0 332 002 161**

#### Technical data

Resistive load	Switching current/no. of operations	A/Thousand	75 / $\geq$ 125
Resistive load	Short-time load $\leq$ 1 s	A	400
Response/release voltage		V/V	$\leq$ 5,5/0,5...4,0
Response/release time		ms/ms	$\leq$ 10 / $\leq$ 10
Contact type			single
Bracket			fixed
Overall resistance		$\Omega$	20 $\pm$ 3

#### Dimensional drawing

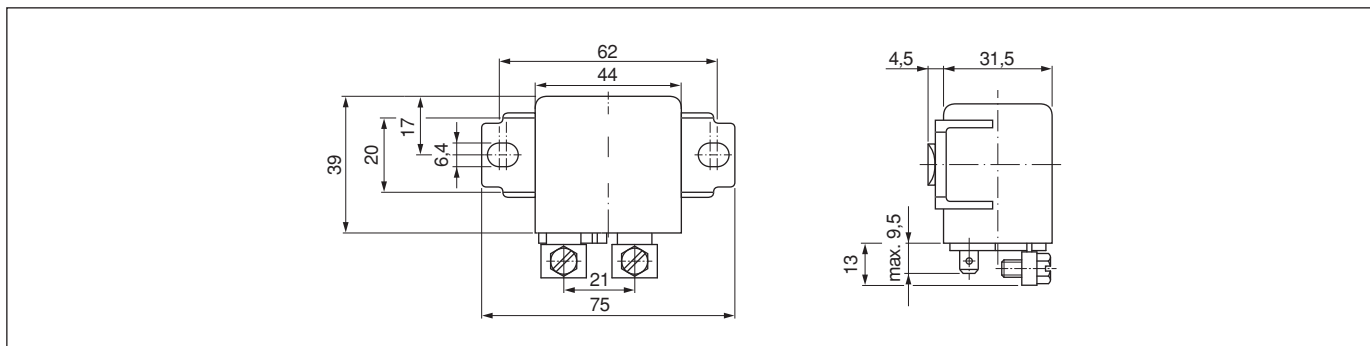

Accessories: Double receptacle housing for excitation side (terminals 85 and 86). Order using Tyco (AMP) number 180 907 from: Tyco (AMP) Deutschland GmbH, Amperestraße 7-11, D-63225 Langen, Tel. 0 61 03/70 90.

#### Figure

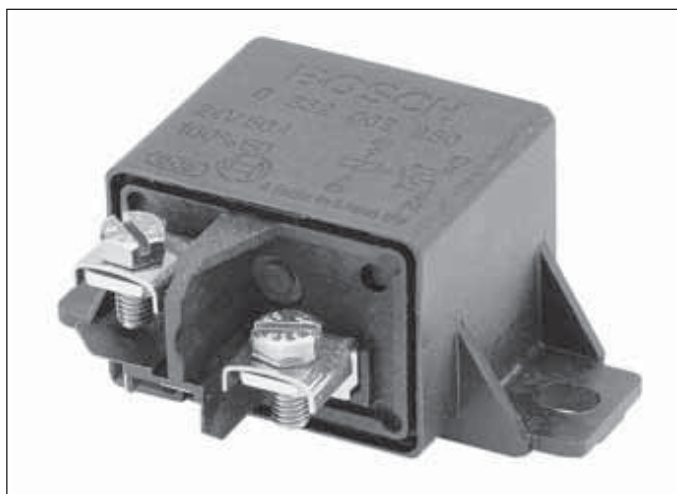

#### Connection and circuit diagram

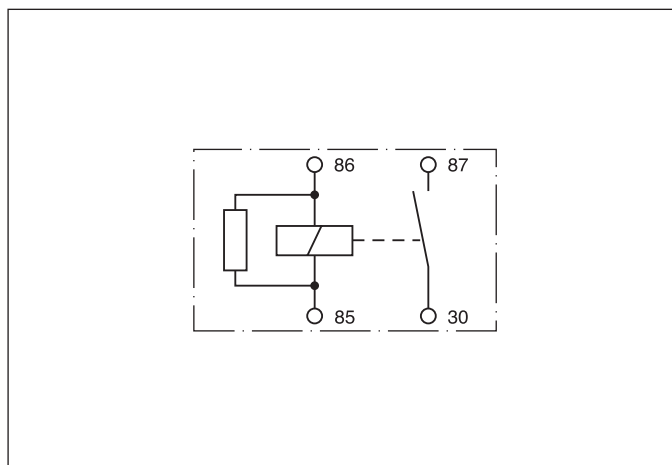

Polarity: Terminal 86 and terminal 30 to +

# Relays

## Power relays

### Make relay 24 V type 2

0 332 002 250

#### Technical data

Resistive load	Switching current/no. of operations	A/Thousand	50 / $\geq$ 100
Resistive load	Short-time load $\leq$ 1 s	A	200
Response/release voltage		V/V	$\leq$ 18,0/1,0...8,0
Response/release time		ms/ms	$\leq$ 10 / $\leq$ 10
Contact type			leading contact
Bracket			fixed
Overall resistance		$\Omega$	130 $\pm$ 10

#### Dimensional drawing

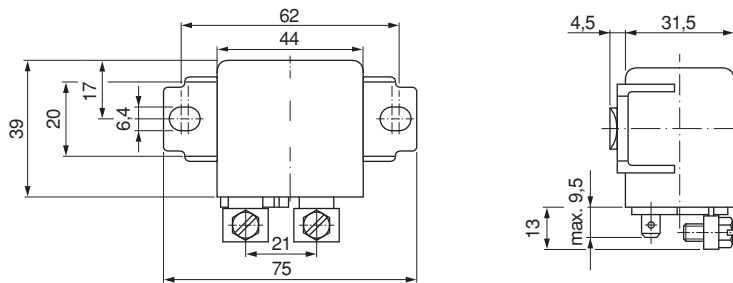

Accessories: Double receptacle housing for excitation side (terminals 85 and 86). Order using Tyco (AMP) number 180 907 from: Tyco (AMP) Deutschland GmbH, Amperestraße 7-11, D-63225 Langen, Tel. 0 61 03/70 90.

#### Figure

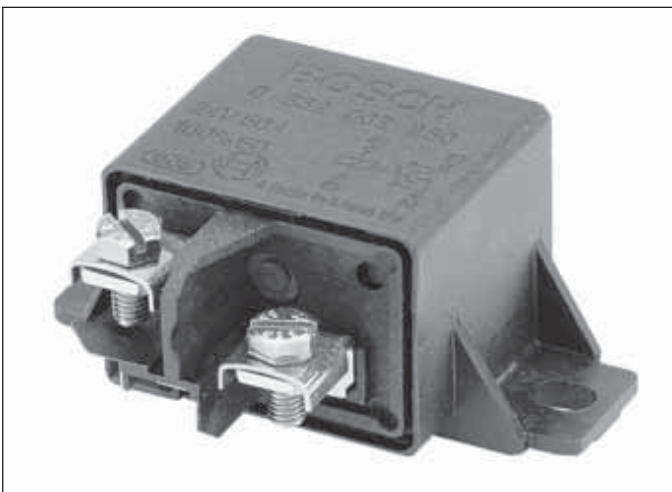

#### Connection and circuit diagrams

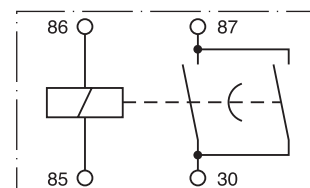

Polarity: Terminal 86 and terminal 30 to +

# Relays

## Power relays

### Make relay 24 V type 2

0 332 002 256

#### Technical data

Resistive load	Switching current/no. of operations	A/Thousand	50 / ≥ 50
Resistive load	Short-time load ≤ 1 s	A	150
Response/release voltage		V/V	≤ 17,0/4,0...8,0
Response/release time		ms/ms	≤ 10 / ≤ 15
Contact type			single
Bracket			fixed
Overall resistance		Ω	130 ± 10

#### Dimensional drawing

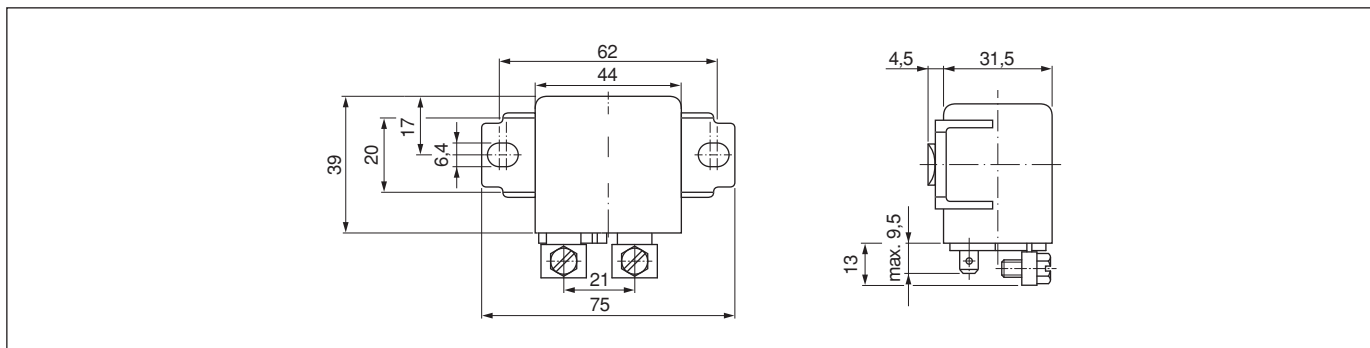

Accessories: Double receptacle housing for excitation side (terminals 85 and 86). Order using Tyco (AMP) number 180 907 from: Tyco (AMP) Deutschland GmbH, Amperestraße 7-11, D-63225 Langen, Tel. 0 61 03/70 90.

#### Figure

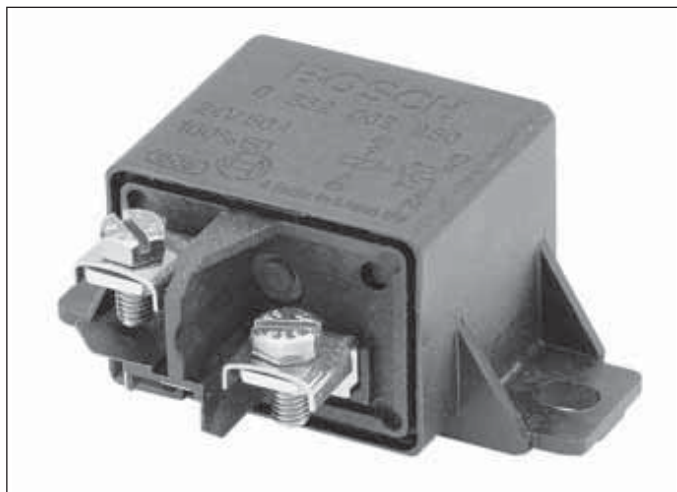

#### Connection and circuit diagrams

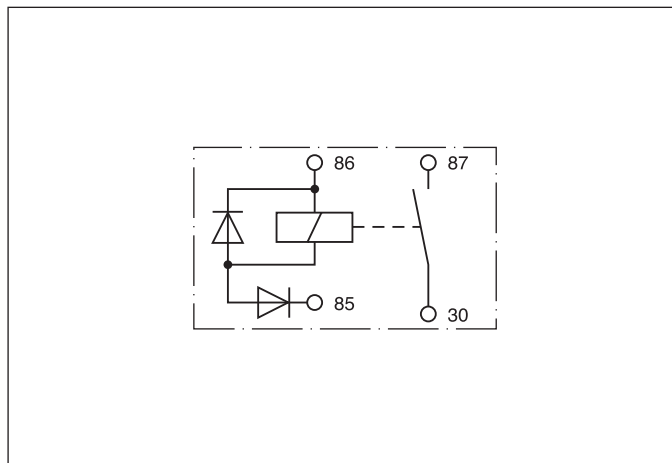

Polarity: Terminal 86 and terminal 30 to +



# Relays

## Power relays

### Make relay 24 V type 2

0 332 002 257

#### Technical data

Resistive load	Switching current/no. of operations	A/Thousand	50 / $\geq 50$
Response/release voltage		V/V	$\leq 18,0/1,0\dots 8,0$
Response/release time		ms/ms	$\leq 10 / \leq 10$
Contact type			single
Bracket			fixed
Overall resistance		$\Omega$	$130 \pm 10$

#### Dimensional drawing

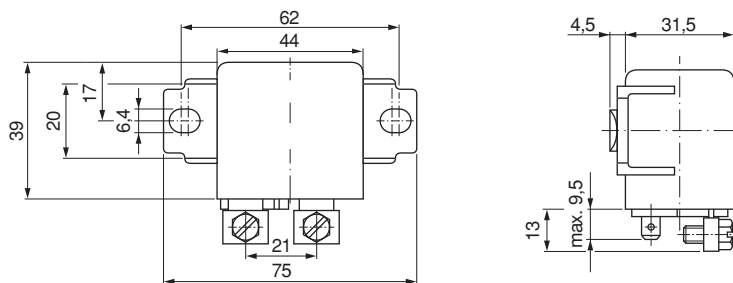

Accessories: Double receptacle housing for excitation side (terminals 85 and 86). Order using Tyco (AMP) number 180 907 from: Tyco (AMP) Deutschland GmbH, Amperestraße 7-11, D-63225 Langen, Tel. 0 61 03/70 90.

#### Figure

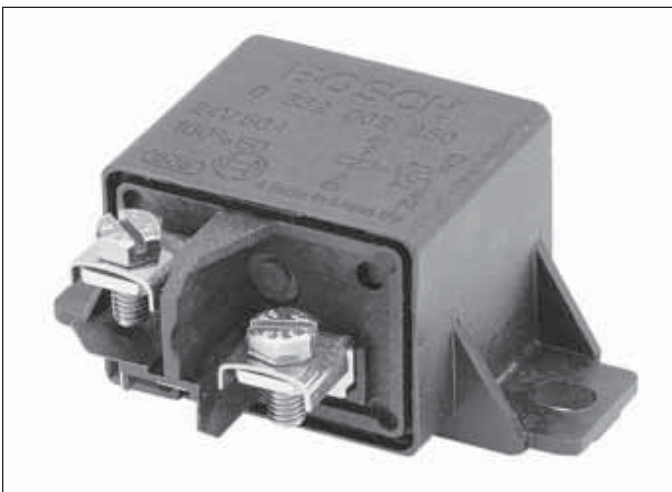

#### Connection and circuit diagrams

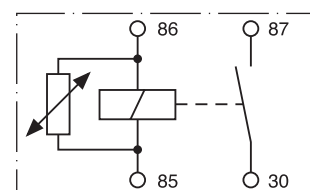

Polarity: Terminal 86 and terminal 30 to +

# Relays

## Power relays

### Make relay 12 V type 3

**0 332 002 351**

#### Technical data

Resistive load	Switching current/no. of operations	A/Thousand	75 / $\geq 200$
Resistive load	Short-time load $\leq 1$ s	A	500
Response/release voltage		V/V	$\leq 8,0/1,5...4,0$
Response/release time		ms/ms	$\leq 10 / \leq 10$
Contact type			twin
Bracket			fixed
Overall resistance		$\Omega$	$46 \pm 5$

#### Dimensional drawing

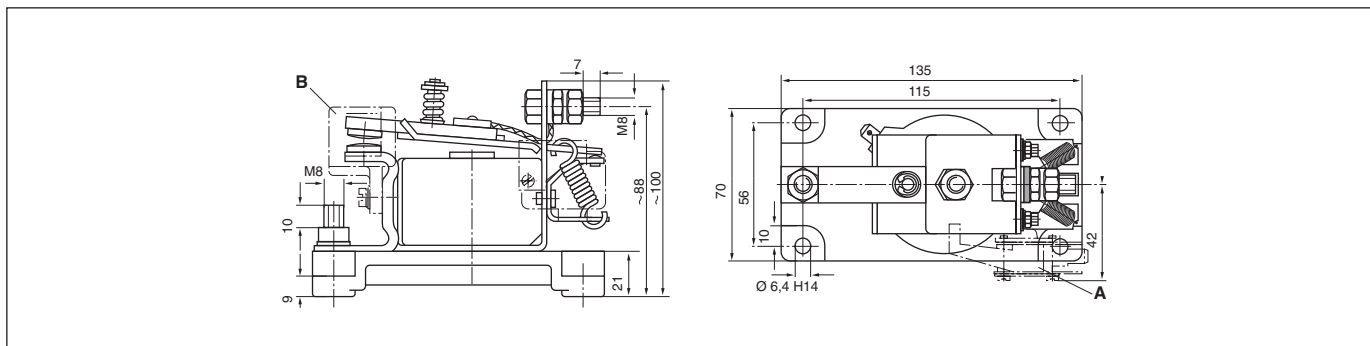

Accessories: Tyco (AMP) Supersal connector; Connector housing no. 282080-1; Contact no. 183025-1 (x2); Single wire seal no. 828920-1 for 1.5mm<sup>2</sup> cable (x2)

#### Figure

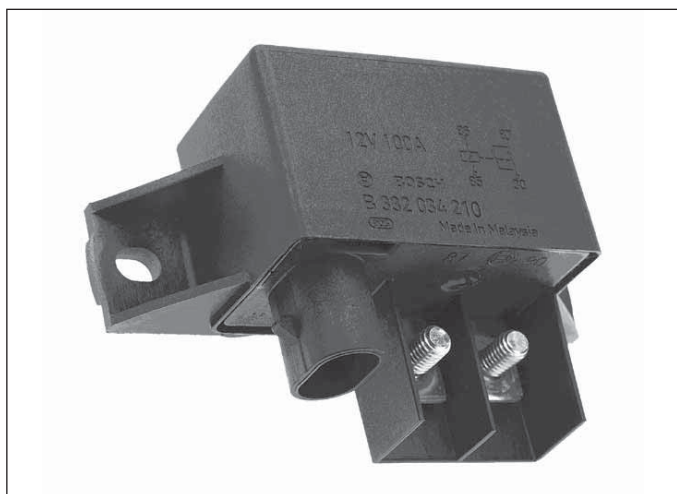

#### Connection and circuit diagram

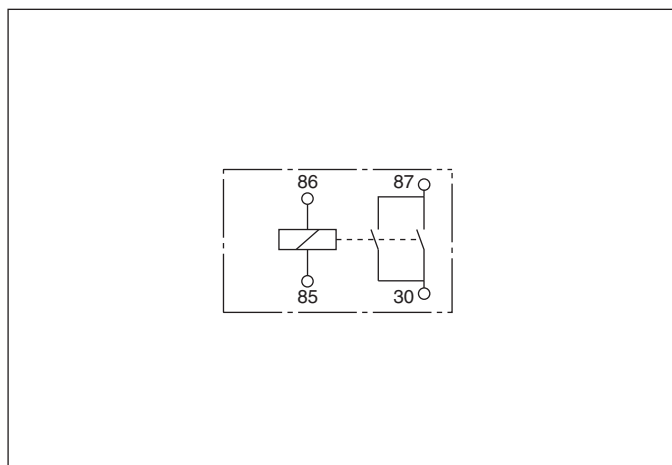

# Relays

## Power relays

### Make relay 12 V type 3

**0 332 002 352**

#### Technical data

Resistive load	Switching current/no. of operations	A/Thousand	75 / $\geq 200$
Resistive load	Short-time load $\leq 1$ s	A	500
Response/release voltage		V/V	$\leq 8,0/1,5...4,0$
Response/release time		ms/ms	$\leq 10 / \leq 10$
Contact type			twin
Bracket			fixed
Overall resistance		$\Omega$	$42 \pm 5$

#### Dimensional drawing

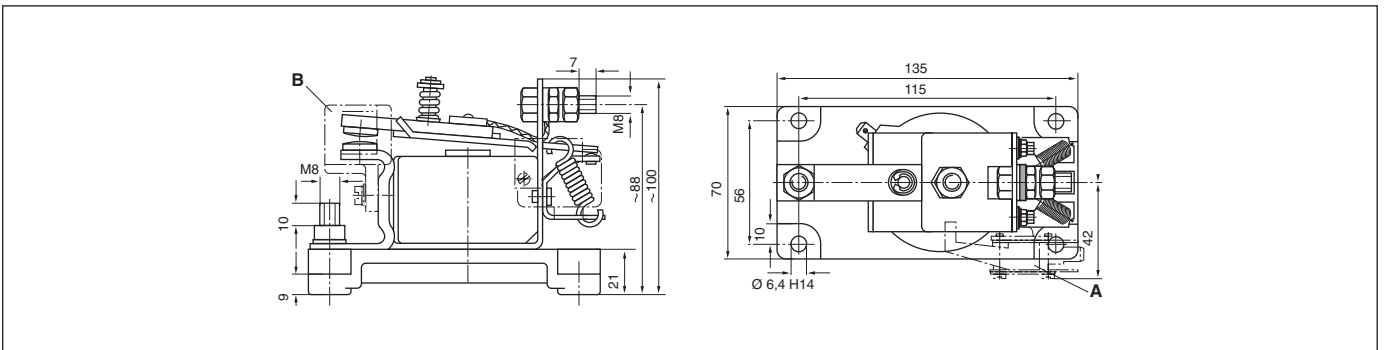

Accessories: Tyco (AMP) Supersal connector; Connector housing no. 282080-1; Contact no. 183025-1 (x2); Single wire seal no. 828920-1 for 1.5mm<sup>2</sup> cable (x2)

#### Figure

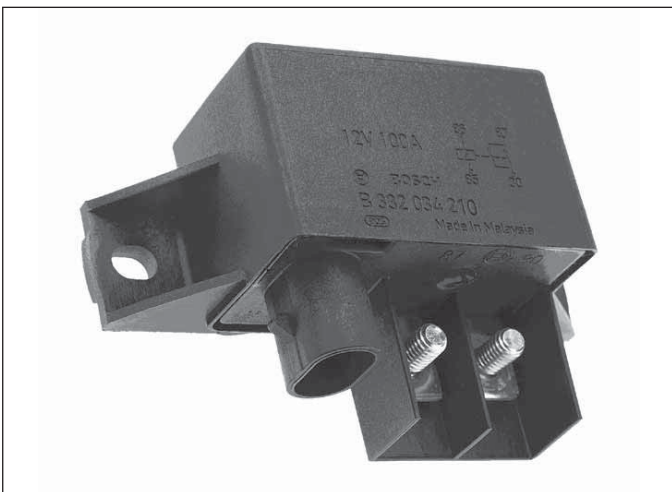

#### Connection and circuit diagram

