

## EVC135 Contactor

- 135A continuous carry
- Hermetically Sealed
- Form X



### Performance Data

Parameter	Units	Values
Contact Arrangement, power contacts		1 Form X (SPST-NO-DM)
Rated Operating Voltage	VDC	100-450 (450-900) <sup>1</sup>
Continuous (Carry) Current, Typical	A	135 @ 85°C (cable 35mm <sup>2</sup> )
Limiting short time circuit @ 85°C, load cable 35mm <sup>2</sup>	A	225A for 360sec
	A	400A for 60sec
	A	1250A Pulsed 10 times capacitive load
Make/Break Cycle	A	See Load Graph on pg 3
Break Current at 450VDC	A	660, 1 cycle
Contact Resistance, Typical @ 100A	mohms	< 0.5
Mechanical Life	Cycles	1,000,000
Operate Time @ 25°C, Max.	ms	25 <sub>2</sub>
Bounce (after close only), Max.	ms	5
Release Time Max	ms	10
Dielectric Withstand Voltage <sub>3,4</sub>	Vdc	2920 / 1mA of leakage current
Insulation Resistance @ 2920VDC	gigaohms	1
Shock, peak, Coil Energized	G	50
Vibration, sine, 55-2,000Hz, peak	G	20
Operating Ambient Temperature	°C	-40 to +85
Weight, Nominal	oz. (g)	6.7 (190)

<sup>1</sup> Voltage between 450 and 900V are capable but are load dependent and require TE Engineering approval.

<sup>2</sup> 25ms @ rated voltage. Operate time of 40ms max occurs when operate voltage is close to actual pick-up.

<sup>3</sup> Meets dielectric strength and insulation resistance requirements according to ISO6469-3, conformity to IEC60664-1 in preparation.

<sup>4</sup> Dielectric Withstand voltage at beginning of life 3,000Vac and end of life is dependent on user characteristics.

### Coil Operating Parameters (96 ohm) with optional Voltage Reduction after Initial Pull-in<sub>5</sub>

Coil Resistance @ 20°C	96 ohm +/- 5%
Pickup Voltage @ 20°C	17.5 Vdc (Max)
Voltage (will operate)	16 - 28 Vdc
Min hold Voltage @ 20°C	19.6 Vdc (Min)
Release Voltage @ 20°C	3.0 Vdc (Min)
Minimum Hold Current at Temperature (Must operate @ 24V for 100ms before reducing to minimum holding current)	210 mA

### Coil Operating Parameters (26 ohm) with optional Voltage Reduction after Initial Pull-in<sub>5</sub>

Coil Resistance @ 20°C	26 ohm +/- 5%
Pickup Voltage @ 20°C	8.8 Vdc (Max)
Voltage (will operate)	9 – 16 Vdc
Min hold Voltage @ 20°C	7.15 Vdc (Min)
Release Voltage @ 20°C	1.0 Vdc (Min)
Minimum Hold Current at Temperature (Must operate @ 12V for 100ms before reducing to minimum holding current)	275 mA

<sup>5</sup> Optional voltage reduction after pickup if further power reduction is desired

### Coil Operating Parameters (15.3 ohm) using Voltage Reduction after Initial Pull-in

Coil Resistance @ 20°C	15.3 ohm +/- 5%
Pickup Voltage @ 20°C	7.5 Vdc (Max)
Min hold Voltage @ 20°C	4.6 Vdc (Min)
Release Voltage @ 20°C	0.85 Vdc (Min)
Minimum Hold Current at Temperature (Must operate @ 12V for 100ms before reducing to minimum holding current)	300 mA

### Coil Operating Parameters (15.3 ohm) and Recommended PWM Parameters

Coil Resistance @ 20°C	15.3 ohm +/- 5%
Pickup Voltage @ 20°C	7.5 Vdc (Max)
Release Voltage @ 20°C	0.85 Vdc (Min)
Frequency	> 15kHz
Operating Voltage	8.0 Vdc to 12 Vdc
Duty Cycle	58% to 72%
Coil Current (minimum recommended RMS)	300 mA

### Coil Operating Parameters (3.8 ohm) using Voltage Reduction after Initial Pull-in

Coil Resistance @ 20°C	3.8 ohm +/- 5%
Pickup Voltage @ 20°C	3.5 Vdc (Max)
Min hold Voltage @ 20°C	2.0 Vdc (Min)
Release Voltage @ 20°C	0.5 Vdc (Min)
Minimum Hold Current at Temperature (Must operate @ 12V for 100ms before reducing to minimum holding current)	500 mA

### Coil Operating Parameters (3.8 ohm) and Recommended PWM Parameters

Coil Resistance @ 20°C	3.8 ohm +/- 5%
Pickup Voltage @ 20°C	3.5 Vdc (Max)
Release Voltage @ 20°C	0.5 Vdc (Min)
Frequency	> 15kHz
Operating Voltage	8.0 Vdc to 12 Vdc
Duty Cycle	25% to 35%
Coil Current (minimum recommended RMS)	500 mA

**EVC135 Contactor (Continued)**

**Outline Dimensions**

**EVC135 Bottom Mount**

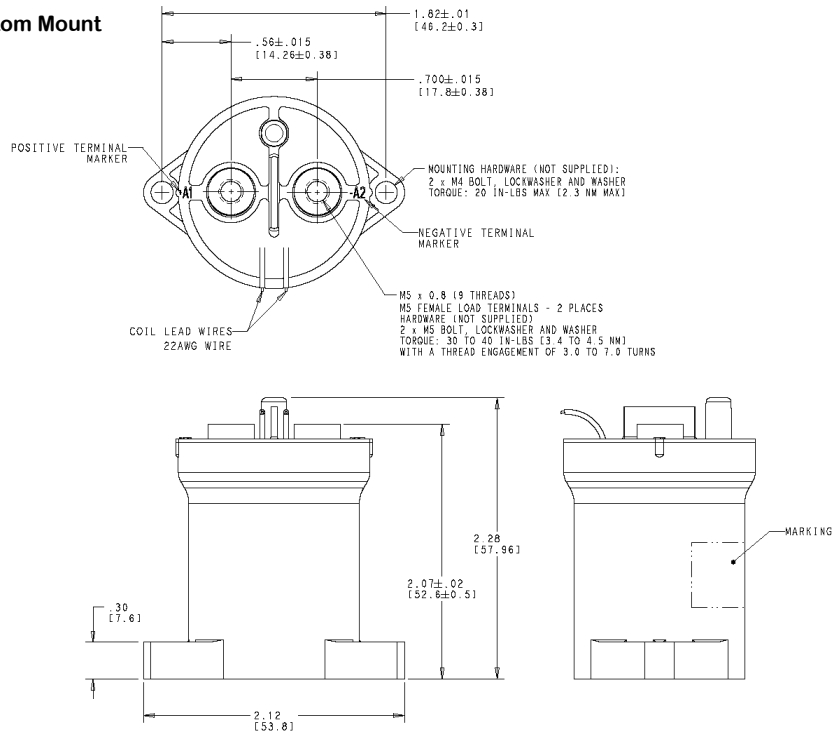

**EVC135 Side Mount**

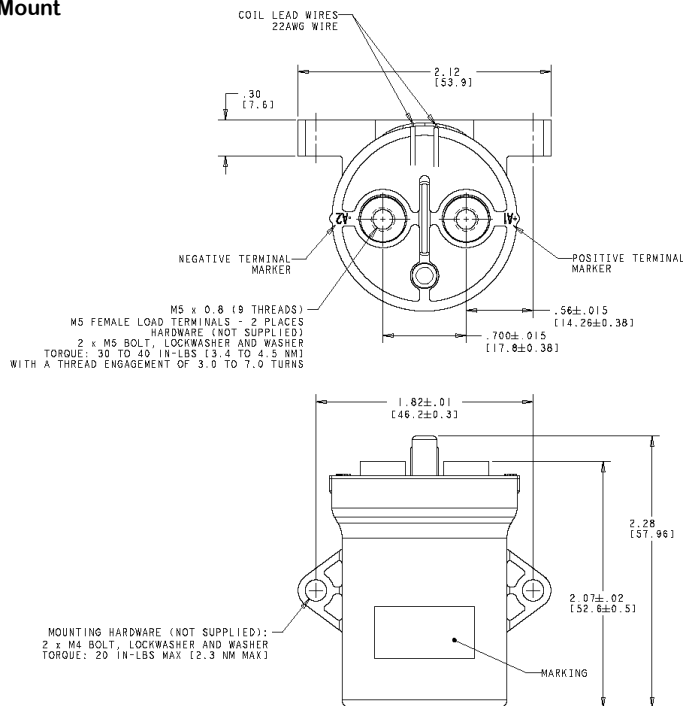

**EVC135 Contactor** (Continued)

**Contact Performance**

**Life Cycles vs Resistive Load at 400Vdc**  
(Chart is for engineering guideline, verification at 2200Vrms for Dielectric Withstanding)

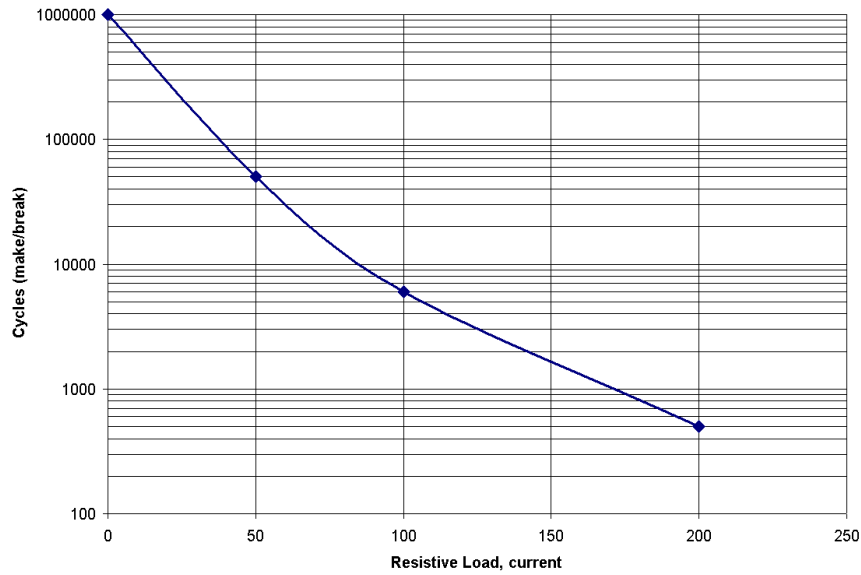

**Note:**

- <sup>1</sup> The maximum make current is 600A to avoid contact welding.
- <sup>2</sup> For reverse current, the performance of the contactor will roughly be reduced by 50% of the cycle life in the forward direction.

**EVC135 Contactor (Continued)**

**Contact Performance**

**Coil Performance (96 ohm)**

Values at 23°C			
Pull-in [V] (must) (max.)	Drop-out [V] (must) (min.)	Hold [V] (must) (min.)	Coil Res. [ohms] (nom.)
17.5	3.0	19.6	96.0

Temp	Pull-in (must) (max.)	Drop-out (must) (min.)	Hold (must) (min.)	Coil Res. (nom.)
-40	13.2181	2.2660	14.8043	72.5108
-30	13.8978	2.3825	15.5655	76.2392
-20	14.5774	2.4990	16.3267	79.9677
-10	15.2571	2.6155	17.0880	83.6961
0	15.9368	2.7320	17.8492	87.4246
10	16.6164	2.8485	18.6104	91.1530
23	17.5000	3.0000	19.6000	96.0000
30	17.9758	3.0816	20.1329	98.6099
40	18.6554	3.1981	20.8941	102.3384
50	19.3351	3.3146	21.6553	106.0668
60	20.0148	3.4311	22.4165	109.7953
70	20.6944	3.5476	23.1778	113.5237
85	21.7139	3.7224	24.3196	119.1164
90	22.0538	3.7806	24.7002	120.9806
100	22.7334	3.8972	25.4614	124.7090
110	23.4131	4.0137	26.2227	128.4375
120	24.0928	4.1302	26.9839	132.1659
130	24.7724	4.2467	27.7451	135.8944

NOTE: These are theoretical values based on the change in resistance of copper over temperature. Actual Values may vary slightly.

**Coil Performance (26 ohm)**

Values at 23°C			
Pull-in [V] (max.)	Drop-out [V] (min.)	Hold [V] (min.)	Coil Res. [ohms] (nom.)
8.8	1.0	7.2	26

Temp	Pull-in (max.)	Drop-out (min.)	Hold (min.)	Coil Res. (nom.)
-40	6.6468	0.7553	5.4005	19.8725
-30	6.9886	0.7942	5.6782	20.8943
-20	7.3304	0.8330	5.9559	21.9161
-10	7.6721	0.8718	6.2336	22.9380
0	8.0139	0.9107	6.5113	23.9598
10	8.3557	0.9495	6.7890	24.9816
20	8.6975	0.9883	7.0667	26.0035
30	9.0392	1.0272	7.3444	27.0253
40	9.3810	1.0660	7.6221	28.0471
50	9.7228	1.1049	7.8998	29.0689
60	10.0646	1.1437	8.1775	30.0908
70	10.4063	1.1825	8.4552	31.1126
80	10.7481	1.2214	8.7328	32.1344
90	11.0899	1.2602	9.0105	33.1562
100	11.4317	1.2991	9.2882	34.1781
110	11.7734	1.3379	9.5659	35.1999
120	12.1152	1.3767	9.8436	36.2217
130	12.4570	1.4156	10.1213	37.2436

NOTE: These are theoretical values based on the change in resistance of copper over temperature. Actual Values may vary slightly.

**Coil Performance (15.3 ohm)**

Values at 23°C			
Pull-in [V] (max.)	Drop-out [V] (min.)	Hold [V] (min.)	Coil Res. [ohms] (nom.)
7.5	0.9	4.6	15.3

Temp	Pull-in (max.)	Drop-out (min.)	Hold (min.)	Coil Res. (nom.)
-40	5.6649	0.6420	3.4745	11.5564
-30	5.9562	0.6750	3.6531	12.1506
-20	6.2475	0.7080	3.8318	12.7448
-10	6.5388	0.7411	4.0104	13.3391
0	6.8300	0.7741	4.1891	13.9333
10	7.1213	0.8071	4.3677	14.5275
20	7.4126	0.8401	4.5464	15.1217
30	7.7039	0.8731	4.7251	15.7160
40	7.9952	0.9061	4.9037	16.3102
50	8.2865	0.9391	5.0824	16.9044
60	8.5778	0.9721	5.2610	17.4986
70	8.8690	1.0052	5.4397	18.0928
80	9.1603	1.0382	5.6183	18.6871
90	9.4516	1.0712	5.7970	19.2813
100	9.7429	1.1042	5.9756	19.8755
110	10.0342	1.1372	6.1543	20.4697
120	10.3255	1.1702	6.3330	21.0639
130	10.6167	1.2032	6.5116	21.6582

NOTE: These are theoretical values based on the change in resistance of copper over temperature. Actual Values may vary slightly.

**Coil Performance (3.8 ohm)**

Values at 23°C			
Pull-in [V] (max.)	Drop-out [V] (min.)	Hold [V] (min.)	Coil Res. [ohms] (nom.)
3.5	0.5	2.0	3.8

Temp	Pull-in (max.)	Drop-out (min.)	Hold (min.)	Coil Res. (nom.)
-40	2.6587	0.3626	1.5106	2.8702
-30	2.7954	0.3812	1.5883	3.0178
-20	2.9321	0.3998	1.6660	3.1654
-10	3.0689	0.4185	1.7437	3.3130
0	3.2056	0.4371	1.8213	3.4606
10	3.3423	0.4558	1.8990	3.6081
20	3.4790	0.4744	1.9767	3.7557
30	3.6157	0.4930	2.0544	3.9033
40	3.7524	0.5117	2.1320	4.0509
50	3.8891	0.5303	2.2097	4.1985
60	4.0258	0.5490	2.2874	4.3461
70	4.1625	0.5676	2.3651	4.4936
80	4.2992	0.5863	2.4428	4.6412
90	4.4360	0.6049	2.5204	4.7888
100	4.5727	0.6235	2.5981	4.9364
110	4.7094	0.6422	2.6758	5.0840
120	4.8461	0.6608	2.7535	5.2316
130	4.9828	0.6795	2.8311	5.3792

NOTE: These are theoretical values based on the change in resistance of copper over temperature. Actual Values may vary slightly.

**EVC135 Contactor** (Continued)

**Contact Performance**

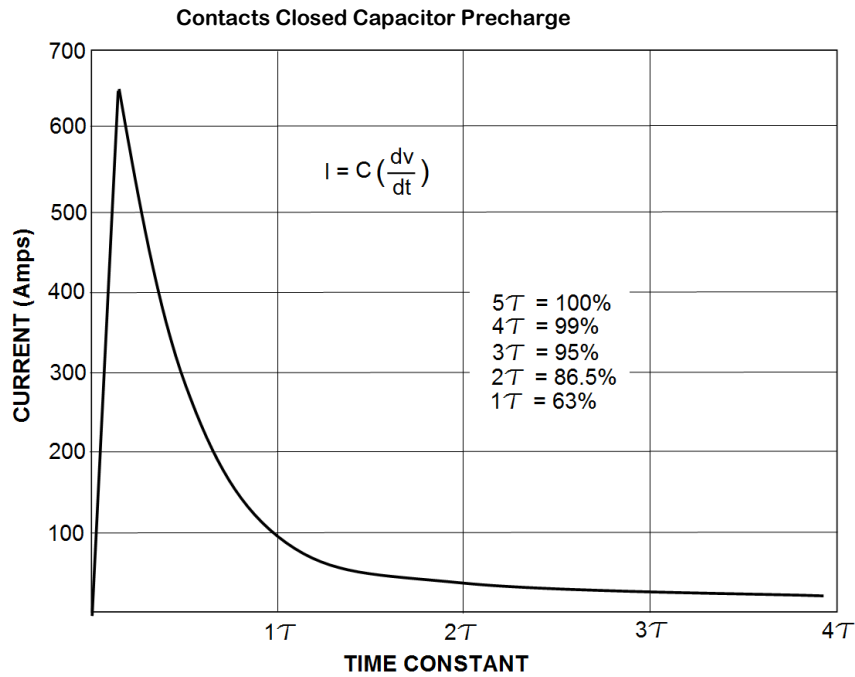

**Notes:**

- 1) Because higher current causes more damage to contact surface, at least 95% Pre-charge is recommended.
- 2) In rush current dependent upon RC time constant and pre-charge timing sequence.

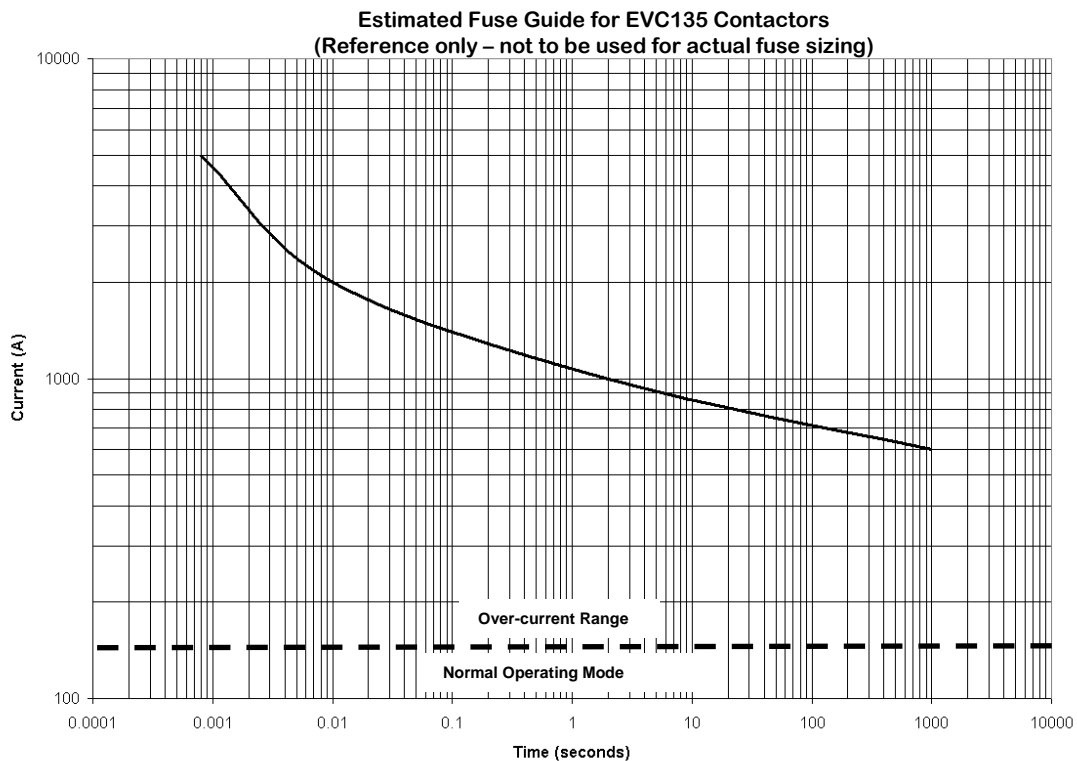



---

**EVC135 Contactor** (Continued)

---

**Descriptive Part Number:** EVC 135 -4 B N G -xx

**Series:** EVC135 = 135A Continuous Current Contactor

**Coil Voltage:** 4 = 12VDC (15.3 Ohm Coil) 5 = 12VDC (26 Ohms Coil) 6 = 12VDC (3.8 Ohms Coil) 7 = 24VDC (96 Ohm coil)

**Coil Wire Length:** A = 15 inches (380 mm) B = 6 inches (150 mm)

**Coil Termination:** N = None - Stripped Wires C = Customer Specified Connector

**Mounting and Power Terminals:** G = Bottom Mount (2 x #8); M5 x 10 H = Side Mount (2 x #8); M5 x 10

**Special:** -xx Special Order