

VTM-1 Series, Specification Grade, On-Delay, Timing Module



Timing Specifications

Timing Mode — On-Delay — VTM-1 in-line timing module is wired in series with the load circuit. Time delay is initiated when power is applied to the series network. Connecting a resistor across the center terminals provides tamper-proof setting of time delay from 1-1000 sec.

Timing Ranges — 1 to 1,000 sec.

Timing Adjustment — Time delay is set by connecting an appropriately rated resistor or potentiometer between the center two terminals. As supplied, the unit provides a nominal 1 second delay. Add 10k ohm of resistance for every additional second of delay required. For example: 5 seconds = 40k ohms; 10 seconds = 90k ohms.

Accuracy — Repeat Accuracy — ±2%

Reset Time — 100 ms, max., in the timing or time-out condition.

Output Switch Data

Arrangement — 1 Form A (SPST-NO)

Rating — 5A, inductive, at nominal operating voltage.

Inrush — Not to exceed 10A for one cycle.

Max. Leakage Current — 4mA rms

Expected Electrical Life — 10,000,000 operations at rated load.

Initial Dielectric Strength — Between Active Terminals and Outside of Case — 1,480VAC for one min.

Input Data @ 25°C

Operating Voltage — Universal — 24-240VAC/VDC (19-288VAC/VDC).

Current — 2mA (max.) required to operate timer regardless of output state.

Power Requirement — 3W max.

Transient Protection — MOV across input 2,000V for 11µs on line side of load.

Environmental Data

Temperature Range — Storage — -40°C to +85°C
Operating — -30°C to +65°C

Mechanical Data

Mounting — Screw mount in horizontal or vertical position through built-in mounting ears.

Termination — 0.250 in (6.35) quick connect terminals for input line, load output and timing resistor connection.

Weight — 3 oz. (84g) approximately

Product Facts

- On-delay timing mode
- Timing from 1 to 1000 sec.
- 1A solid state SPST-NO output
- 0.25" (6.35) quick connect terminals
- Universal voltage: 24 to 240VAC/VDC
- Rated to 10 million operations
- File E60363, File LR51332

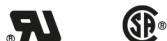

Users should thoroughly review the technical data before selecting a product part number. It is recommended that user also seek out the pertinent approvals files of the agencies/laboratories and review them to ensure the product meets the requirements for a given application.

Dalroad

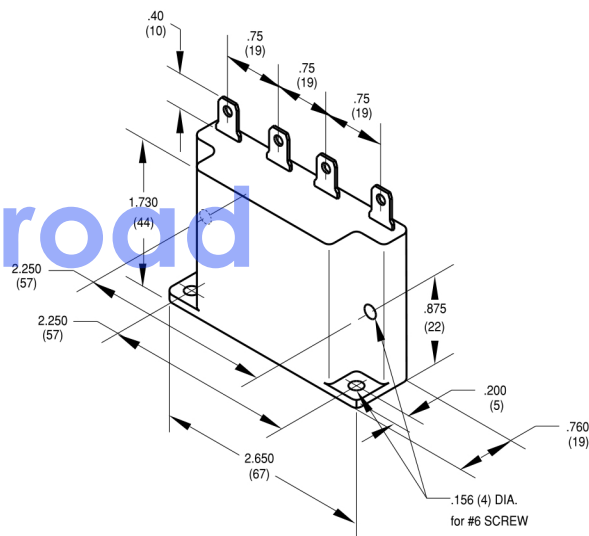

Outline Dimensions

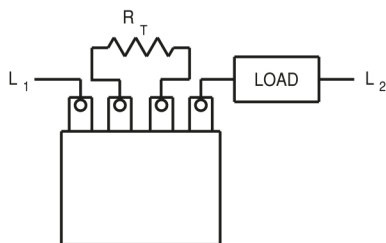

Wiring Diagram

Ordering Information

Part Number	Mode	Input Voltage
VTM-1	On-Delay	24-240VAC or VDC

Notes:

1. Do not operate timer without connecting load in series with line voltage.
2. For a time delay of 1 second, connect a jumper across the center two terminals.

Authorized distributors are likely to stock the following:

VTM-1