

High Voltage Contactors ECK200 Series

- ❑ Hermetically sealed with ceramic technology
- ❑ Designed with built-in economizer, hold power 1.7W
- ❑ Maximum DC breaking current at 2000A
- ❑ Maximum DC breaking voltage at 1000VDC
- ❑ Auxiliary contact version available
- ❑ Comply with DC-1 utilization category in IEC60947-4-1

Typical applications

DC Charging station, Electric vehicle, AGV, Electric forklift, Energy storage systems, Photovoltaic inverter



Approvals

UL,CCC,TUV,CE - To be added.

Main Contact Data

Continuous Carry Current	250A
Rated Switching Current	200A
Maximum Switching Voltage	1000VDC
Contact Arrangement	1 Form X (SPST-NO-DM)
Initial Voltage Drop	≤ 0.4mΩ (200A, after 1 minute)
Operate Time, max. (at 23°C)	30ms
Release Time, max. (at 23°C)	10ms
Mechanical Life	500,000 cycles

Insulation Data

Dielectric Withstand Voltage (leakage current <1mA)	
between open main contacts	2,500Vrms
between main contact and coil	3,500Vrms
between main contacts and aux contacts	2,500Vrms
between open aux contacts	750Vrms
Initial Insulation Resistance @ 500VDC	
between insulated elements	> 1x10 ⁹ Ω

Other Data

Material Compliance: EU RoHS/ELV, China RoHS, REACH, Halogen content refer to the product Compliance Support Center at www.te.com/customer-support/rohssupportcenter

Ambient Temperature	-40°C to 85°C
Vibration Resistance (functional)	Sine, 10-2000Hz, 4.5G
Shock Resistance (functional)	11ms 1/2 Sine, Peak 20G
Terminal Type	Screw for contact, wire for coil
Weight	380g
Packaging/unit	box/24 pcs.

Contact Ratings

Load	Cycles
200A, 450VDC, make/break, resistive	6,000
200A, 1000VDC, make/break, resistive	1,000
600A making, resistive	6000

CE Specification (IEC60947-4-1)

Rated Operational Current	Utilization Category	Switching Cycles
100A	DC-1	6,050

Auxiliary Contact Data

Contact Form	1 Form A (SPST-NO)
Contact Current, Max.	2A, 30VDC
Contact Current, Min.	10mA, 8VDC
Contact Resistance, Max.	0.4Ω @ 30VDC / 0.15Ω @ 125VAC

Coil versions, DC coil

Coil Code	Nominal Voltage	Nominal Operating Current	Max Starting Current	Operate Voltage	Maximum Operate Voltage	Release Voltage	Coil Power
A	9-36VDC	0.13A@12VDC 0.07A@24VDC	3.6A	≤9VDC	36VDC	≥3VDC	Start: 43.2W Hold: 1.7W

All figures are given for coil without pre-energization, at ambient temperature +23 °C.

Current Endurance Capacity Curve

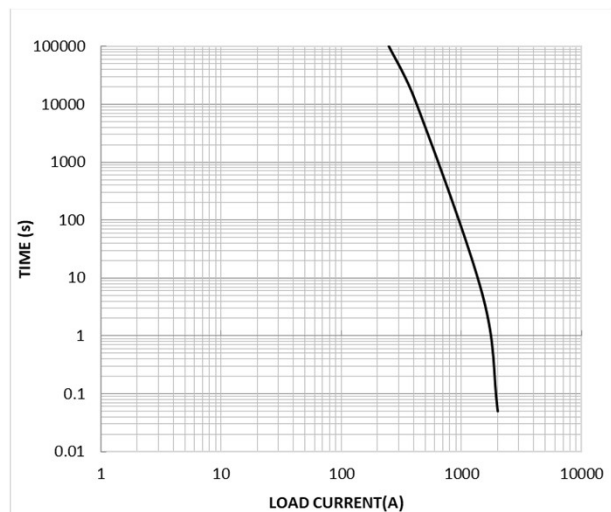

Note: The data is measured at the environment temperature 85°C with cross section area of wire 150mm² min.

High Voltage Contactors ECK200 Series

Estimated Make & Break Power Switching Ratings

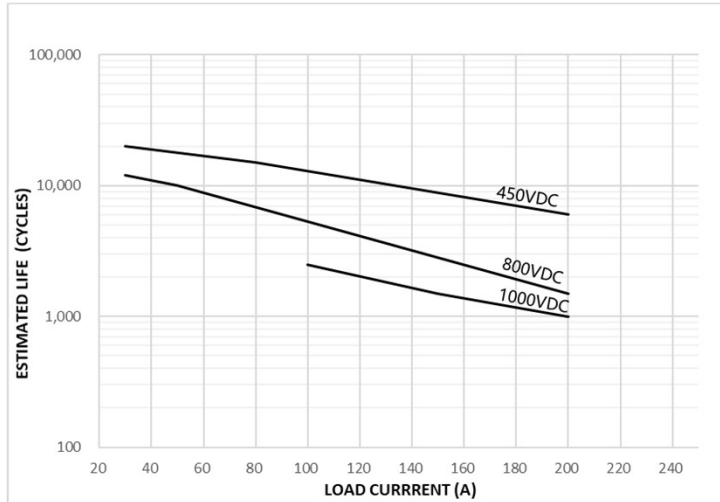

Note:

1. The curve was created based on extrapolated data with few typical points, users are recommended to confirm performance in actual application.
2. The typical data were estimated with resistive load at room temperature.

Dimension

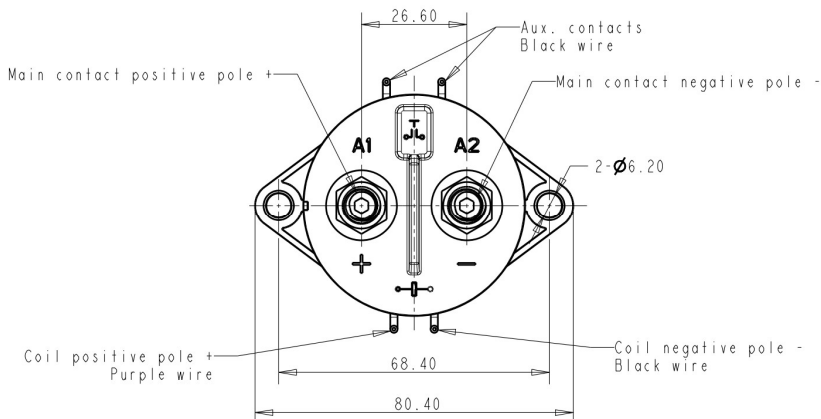
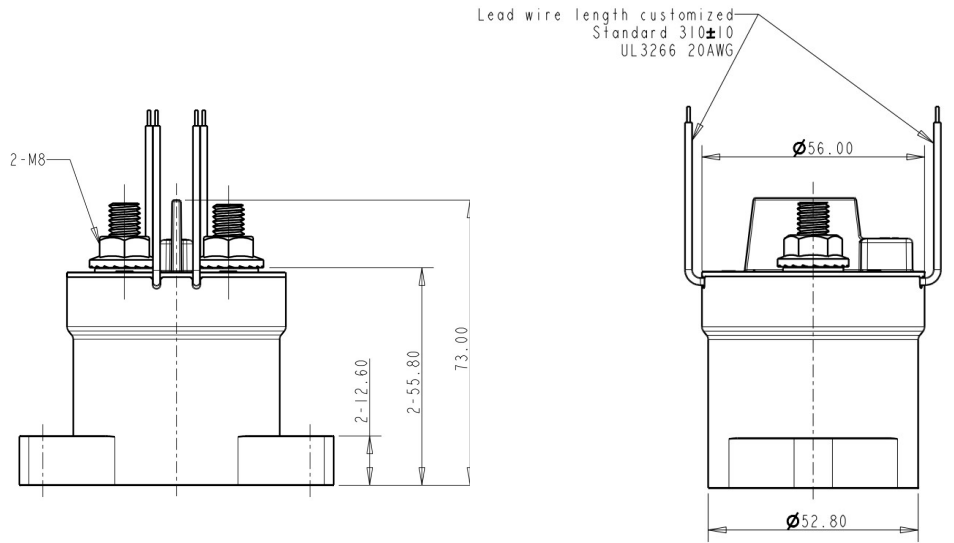

Circuit Diagram

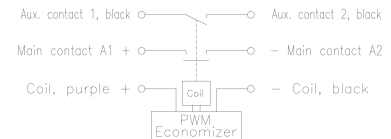

General tolerance	
Dimension	Tolerance
<10	±0.3
10-50	±0.6
>50	±1.0

High Voltage Contactors ECK200 Series

Product Nomenclature

	ECK200	H	A	A	P	A	,XX
Product series ECK200 = 200A contactor							
Contact form A = Normally Open, without auxiliary contacts H = Normally Open + N.O. auxiliary contacts							
Coil Voltage A = 9-36Vdc							
Coil Termination A = Flying leads B = Connector							
Coil Control Mode P = Built-in PWM economizer							
Mounting position A = Bottom mount							
Customer Special Designator Blank = Standard version XX = 2 digit or letter specified by manufacturer							

Product Part Number Table

Product Code	Contact Form	Mounting Position	Coil	Coil Control Mode	Part Number
ECK200AAAPA	Normally Open	Bottom	9-36VDC	Built-in PWM economizer	1-2071567-2
ECK200HAAPA	Normally Open + NO Aux Contact				1-2071567-1

Note: Only typical part numbers are listed above, other types please contact TE engineer.

Cautions

- Do not use the product when product is dropped or broken.
- Avoid mounting the contactor main contact terminals in downward direction, otherwise the contactor performance will not be guaranteed.
- Please use correctly according to the mark on the surface of the product. Main contact terminals and coil wires have polarity difference. When the connection polarity is reversed, the electrical characteristics promised in the datasheet will not be guaranteed.
- Please drive the product coil through the fast rising (step type power supply mode), otherwise the contactors will not operate.
- If using with diodes for coil, it may lead to a decline in product switching performance.
- Please consider electromagnetic interference when using the product.
- Screw locking torque of main contact terminals should be 10-12 N-m for M8 screw. Screw locking torque of product bottom mounting should be 6-8 N-m for M5 screw.